

文章编号 1004-924X(2009)06-1367-06

# 用于多频振动的 MEMS 复合式能量采集器的设计

任 婧, 陈旭远

(厦门大学 萨本栋微机电研究中心, 福建 厦门 361005)

**摘要:** 设计、模拟了一款用于多频振动的 MEMS 复合式能量采集器, 提出了一种新颖的能量采集结构, 即将压电式悬臂梁和可变电容器结合起来用于多频振动能量的采集。在建立多频振动能量采集系统分析模型的基础上, 使用 MatLab/SIMULINK 的数值模拟, 预测了功率输出。模拟结果显示, 该结构可在 630~655 Hz 有效工作, 在负载为 50 k $\Omega$  时, 输出功率可达 13.46  $\mu$ W。基于这个结果, 给出了一个优化设计方案, 同时为了防止结构失效, 对结构进行了有限元仿真分析。仿真分析结果显示了良好的预期性能, 说明了该设计指导思想的合理性和先进性。

**关键词:** 振动能量采集; 复合式采集器; 多频能量采集; 微机电系统

中图分类号: TN384; TN712 文献标识码: A

## Design of MEMS hybrid energy generator for multi-frequency vibration

REN Jing, CHEN Xu-yuan

(*Pen-Tung Sah MEMS Research Center, Xiamen University, Xiamen, 361005 China*)

**Abstract:** The design, modeling and simulation of a novel MEMS hybrid energy generator for multi-frequency vibration is presented to meet the requirements of portable and wireless electronic devices for collecting energy from the ambient environment. In this design, piezoelectric cantilever beams and capacitors are combined for harvesting the hybrid vibration energy. Then, an analytical model is established for the multi-frequency vibration energy harvesting system and a numerical simulation method is used to predict the power output by using a MatLab/SIMULINK. The result shows that the structure can work efficiently in the frequency ranges of 630–655 Hz, and the power output can reach about 13.46  $\mu$ W with a load resistance of 50 k $\Omega$ . Based on the result, an optimized multi-frequency hybrid energy harvester is designed in this paper. In addition, the Finite Element Analysis (FEA) of the structure is carried out to prevent the structure failure. The work implemented by this paper shows that the next generation design with a wider frequency range and a higher power output within a smaller structure volume is expectant.

**Key words:** vibration energy harvesting; hybrid generator; multi-frequency energy harvesting; MEMS

**Received date:** 2009-01-20; **Revised date:** 2009-04-30.

**Foundation item:** Supported by the National Natural Science Foundation of China (Grant No. 50575191); the Science and Technology Program of Xiamen (Grant No. 3502Z20063006)

## 1 Introduction

Since the current use of batteries as the power source for portable and wireless electronics results in periodic replacement actions, harvesting power from vibration source existing in environment draws a great attention all over the world. Typically, vibration energy can be converted to electrical energy utilizing three mechanisms: electrostatic, electromagnetic, and piezoelectric effects<sup>[1]</sup>. Contrastively, electromagnetic mechanism is difficult to fabricate with MEMS techniques. Meanwhile piezoelectric and electrostatic (capacitive) mechanisms are easier to be integrated in micro-systems, although an additional bias voltage is required for capacitive converters<sup>[2]</sup>. Generally, vibration energy harvesters are based on the widely used mass-spring-damping model. Energy generators provide the maximum output when operated at resonance, and they are inefficient when the driving frequency from environment changes over a range. Thus, it is advantageous to create a device that can operate effectively over a frequency range. Many efforts have been made to broaden the working frequency range of energy harvesting device. Jing-Quan Liu et al. developed a piezoelectric power generator array, which can provide a maximum power output of  $3.98 \mu\text{W}$  in the frequency range of  $200\text{--}400 \text{ Hz}$ <sup>[3]</sup>. Vinod R Challa et al. developed a magnetic-based approach to successfully harvest vibrations within frequency range of  $22\text{--}32 \text{ Hz}$  using a piezoelectric cantilever beam with a natural frequency of  $26 \text{ Hz}$ <sup>[4]</sup>. However, some of these structures are larger than most MEMS devices and difficult to be integrated with MEMS. Furthermore, because most sources in ambient vibrations are in low frequency ( $<1\ 000 \text{ Hz}$ ), working frequency range of the energy harvesters need to match these range

for optimizing output power density.

In this paper, a novel design of hybrid energy generator for multi-frequency energy harvesting is presented. The design combines the capacitive transduction principle with the piezoelectric transduction principle, which makes the structure to convert vibration energy to electrical energy efficiently in a frequency range of  $630\text{--}655 \text{ Hz}$ .

## 2 Design and modeling for hybrid energy harvester

### 2.1 Design principle

Structure of the hybrid energy harvester is schematically shown in Fig. 1 (for a better perspective, the upper part which should be parallel to the lower part has not been rightly positioned). Two seismic masses are respectively suspended by four PZT cantilever beams. Pt and Al electrodes are sputtered on the opposite surface of the two masses, which provide an external bias voltage of  $2.27 \text{ V}$  for charging the capacitor due to working function difference. Different thickness of the two masses differentiates the natural frequency of the upper and lower piezoelectric converter. When the structure is stimulated by external vibration, PZT film on cantilever beam will be tensed or compressed, which in turn induces charge shift and accumulation due to 31 mode piezoelectric effect used in this design.

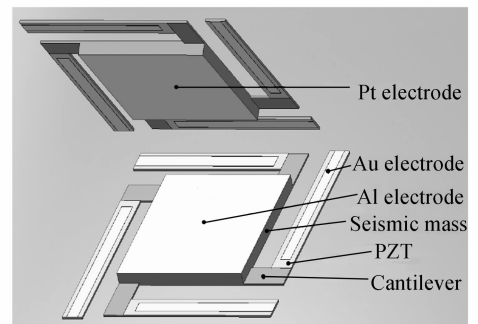

Fig. 1 Opened structure

Meanwhile, the displacements of the two masses alter the distance between the electrodes, and charges will be generated and stored by outside circuit. The physical principle for designed hybrid energy generator is shown in Fig. 2.

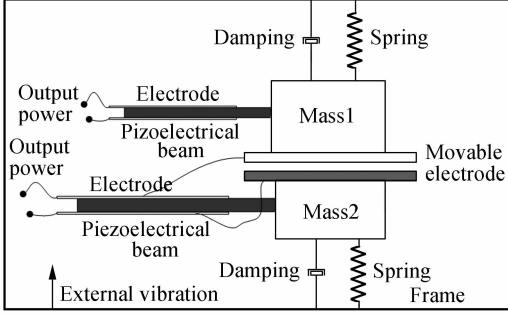

Fig. 2 Principle model of the generator

## 2.2 Analytical modeling

Based on the mass-spring-damper model, the vibration system can be presented as equation (1):

$$m \cdot a = m \cdot \frac{d^2 z}{dt^2} + (b_m + b_e) \cdot \frac{dz}{dt} + k \cdot z + F_{\text{ele}}, \quad (1)$$

where  $F_{\text{ele}}$  is the electric field force between the two electrodes and is given as equation (2):

$$F_{\text{ele}} = \frac{Q^2}{2 \cdot \epsilon \cdot A} = \frac{\epsilon \cdot A \cdot V^2}{2 \cdot z^2}, \quad (2)$$

Where  $m$ ,  $a$ ,  $b_m$ ,  $b_e$ ,  $k$ ,  $A$ ,  $Q$ ,  $V$ ,  $\epsilon$ ,  $z$  are respectively the mass, acceleration amplitude, mechanical damping ratio, electrical damping ratio, elasticity coefficient, area of capacitor electrode, charge in capacitor, bias voltage of the capacitance, dielectric constant, and distance between the two electrodes.  $z$  is determined by the displacements  $z_1$  and  $z_2$  from mass1 and mass2 respectively, and the initial distance  $g_0$  between the two masses is determined by

$$z = z_1 + g_0 - z_2. \quad (3)$$

Current generated from the structure consists of two parts: one part from the PZT on the cantilever beams, and another part from the capacitive

generator. The two parts of current can be expressed as<sup>[5]</sup>:

$$i_{\text{cap}} = \frac{dQ}{dt} = \frac{d}{dt}(V \cdot C) = V \cdot \frac{dC}{dt} = \epsilon \cdot A \cdot V \cdot \frac{d}{dt} \frac{1}{z} = \frac{\epsilon \cdot A \cdot V}{z^2} \cdot \frac{dz}{dt}, \quad (4)$$

$$i_{\text{pzt1}} = \dot{Q}_1 = \frac{d_{31} \cdot k'_1 \cdot l_{\text{PZT}}}{t_{\text{PZT}}} \cdot \dot{x} = \frac{d_{31} \cdot \frac{Y_{\text{PZT}} \cdot \omega_{\text{PZT}} \cdot t_{\text{PZT}}}{l_{\text{PZT}}} \cdot l_{\text{PZT}}}{t_{\text{PZT}}} \cdot \dot{x}_1 = d_{31} \cdot Y_{\text{PZT}} \cdot \omega_{\text{PZT}} \cdot \dot{x}_1 \approx d_{31} \cdot Y_{\text{PZT}} \cdot \omega_{\text{PZT}} \cdot \left| \frac{z_1}{l} \right| \cdot \frac{dz_1}{dt}, \quad (5)$$

Where  $C$  is the inherent capacitance of the capacitor, and  $d_{31}$ ,  $Y_{\text{pzt}}$ ,  $\omega_{\text{pzt}}$ ,  $l$  are respectively the piezoelectric strain coefficient, Young's modulus of PZT film, width of PZT film, and length of the beam. In the equivalent circuit of this hybrid structure, capacitive part can be considered as a parallel connection of a fixed capacitor and an AC current source. PZT film on cantilever beam is also considered as parallel connection of inherent capacitance of PZT and AC current source. Since the system can be simplified as a linear spring damper system<sup>[6]</sup>, power output of the system can be presented as:

$$P = \frac{1}{2} \cdot b_e \cdot \left( \frac{dz}{dt} \right)^2 = i_k^2 \cdot R = (4 \cdot I_{\text{pzt1}} + 4 \cdot I_{\text{pzt2}} + I_{\text{cap}})^2 \cdot R. \quad (6)$$

## 3 Power output and discussion

ANSYS is utilized for structure optimization. Natural frequency of the upper and lower piezoelectric configuration are found as 605.64 Hz and 636.04 Hz. Optimized parameters of the structure are given in Tab. 1.

**Tab. 1 Important parameters**

Symbol	Description	Value	Units
$h_1$	Thickness of mass 1	500	$\mu\text{m}$
$h_2$	Thickness of mass 2	450	$\mu\text{m}$
$l$	Length of the device	10 000	$\mu\text{m}$
$l_m$	Length of the mass	6 000	$\mu\text{m}$
$w_{si}$	Width of cantilever beam	960	$\mu\text{m}$
$L_{si}$	Length of cantilever beam	9 000	$\mu\text{m}$
$g_0$	Initial distance between the two capacitor electrodes	6	$\mu\text{m}$
$d$	Thickness of PZT film	1	$\mu\text{m}$
$Q_m$	Quality factor	100	

MatLab/SIMULINK is employed for the model simulation. Fig. 3 and Fig. 4 show the power output versus the amplitude and frequency of stimulation vibration for both piezoelectric and capacitive convertors. It can be seen that the power outputs of both the piezoelectric and capacitive convertor increase with the amplitude of stimulation vibration. For the piezoelectric part, the power output reaches maximum at the resonance frequency (605.8 Hz). But for the capacitive part, the power output is not a strict resonant mode, and comes in a range of frequency due to the existence of electric field force  $F_{ele}$ , turning resonance frequency of the upper and lower cantilever beams.

As for the hybrid structure, since the ambient vibration frequency may vary in a range, the op-

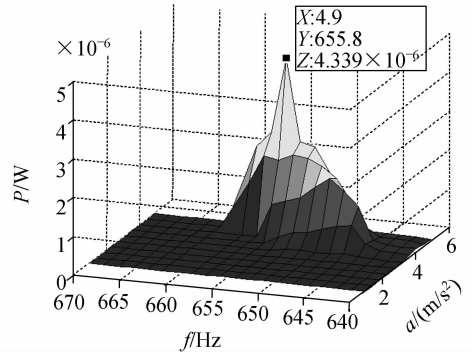

Fig. 4 Power output of capacitor

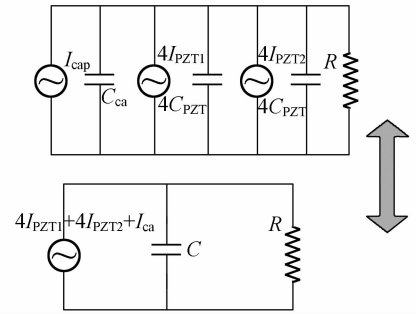

Fig. 5 Equivalent circuit of hybrid system

timized load resistance in Fig. 5 is not a fixed value according to  $R_l = 1/\omega \cdot C$ . Therefore, a load resistance of 50 k $\Omega$  is applied in the system circuit for simulation. Fig. 6 shows the power output versus stimulation frequency. It can be seen that the power output of this hybrid structure has two peak values, respectively at 637.1 Hz and 648 Hz. The maximum power output is 13.46  $\mu\text{W}$ . In addition, the structure can work efficiently in a frequency range of 630~655 Hz.

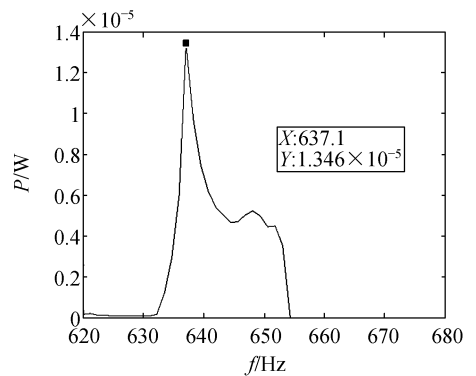

Fig. 6 Power output vs stimulation frequency

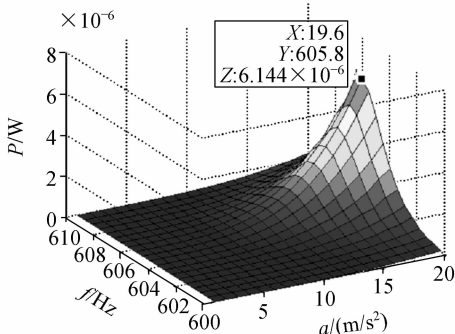

Fig. 3 Power output of cantilever beam

## 4 Finite element analysis

Fig. 7 shows the resonant stress distribution of the upper cantilever beams with a  $500 \mu\text{m}$  mass. An acceleration of  $0.5g$  is applied to the structure, which is larger than the designed  $0.2g$ . Maximum stresses mises on the upper and lower beam are  $31.5 \text{ MPa}$  and  $25.9 \text{ MPa}$ . These two stresses are smaller than the peak tensile strength of PZT- $34.5 \text{ MPa}$ <sup>[7]</sup>. Actually these stresses

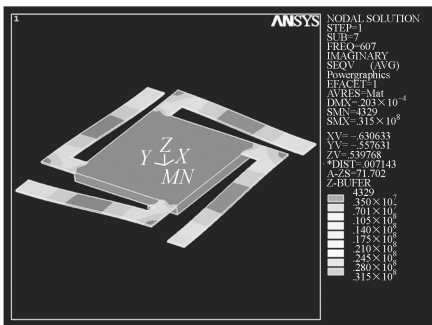

Fig. 7 Stress distribution

## References:

- [1] TANG K H, KAN J W, ZHU G R, *et al.*. Power-supply performance of piezoelectric generator for remote control [J]. *Opt. Precision Eng.*, 2008, 16 (1):92-96. (in Chinese)
- [2] ROUNDY S. A study of low level vibrations as a power source for wireless sensor nodes [J]. *Computer Communications*, 2003, 26(11):1131-1144.
- [3] LIU J Q, FANG H B, XU ZH Y, *et al.*. A MEMS-based piezoelectric power generator array for vibration energy harvesting [J]. *Microelectronics Journal*, 2007:802-806.
- [4] CHALLA V, PRASAD M, SHI Y, *et al.*. A vibration energy harvesting device with bidirectional

cannot be reached in operation since the displacements of seismic masses are limited by a stopper between them. Therefore this design of the structure can work safely.

## 4 Conclusions

In summary, a hybrid micro-power generator for multi-frequency vibration energy harvesting has been developed by combining piezoelectric transduction mechanism with capacitive transduction mechanism. Pt and Al, which have a working function difference of  $2.27 \text{ V}$  are used as the electrodes of the capacitor. By modeling and simulation, the design is optimized. This hybrid energy generator can successfully scavenge vibration energy in a frequency range of  $630 - 655 \text{ Hz}$ . The power output of the hybrid energy generator can reach  $13.46 \mu\text{W}$  with an acceleration of  $0.2g$  and load resistance of  $50 \text{ k}\Omega$ . FEA of the structure proves safety and validity of the structure.

resonance frequency tenability [J]. *Smart Materials and Structural*s, 2008, 17(1):015035.

- [5] KAN J W, TANG K H, WANG SH Y, *et al.*. Modeling and simulation of piezoelectric cantilever generators [J]. *Opt. Precision Eng.*, 2008, 16 (11):71-75. (in Chinese)
- [6] JEON Y B, SOOD R, JEONG J H, *et al.*. MEMS power generator with transverse mode thin film PZT [J]. *Sensors and Actuators A*, 2005, 122(1):16-22.
- [7] LI L T, WU J F, CHU X CH, *et al.*. Finite element analysis and experiment on piezoelectric bimorph [J]. *Opt. Precision Eng.*, 2008, 16 (12): 2378-2383. (in Chinese)

**Authors' biographies:**

**REN Jing** (1984—), female, conducts research at the Department of Mechanical & Electrical Engineering, Xiamen University. Her research interests are various micro vibration energy generators. **E-mail:** renjing99@gmail.com



**CHEN Xu-yuan** (1961—), male, Ph. D., professor of the Department of Mechanical & Electrical Engineering, Xiamen University, his research interests are RF MEMS, Bio-MEMS, etc. **E-mail:** xychen@xmu.edu.cn

**● 下期预告**

## 单晶硅纳米力学性能的试验研究

赵宏伟<sup>1,2</sup>, 闫纪旺<sup>2</sup>, 赵宏健<sup>3</sup>

- (1. 吉林大学 机械科学与工程学院, 中国 长春 130022;
2. 日本东北大学 纳米机械学系, 日本 仙台 519015;
3. 浙江大学 材料与化学工程学院, 浙江 杭州 310027)

对材料纳米力学性能测试手段进行了分析,着重分析了纳米压痕技术的原理和方法,结合纳米压痕技术,采用尖端四面体 Vickers 型单晶金刚石压头对单晶硅(100)晶面进行了纳米压痕实验测试。实验结果表明,在载荷为 1 000 mN 时,晶体硅出现了明显的裂纹和脆性断裂;而在载荷低于 80 mN 的情况下,晶体硅则表现出延性特性。此外,在不同载荷条件下对晶体硅的硬度进行了实验测试,测试结果表明,不同载荷条件下晶体硅的硬度测量值存在较大的差异,导致这种差异的原因在于压痕区域由于晶体硅所受压力的不同,使得晶体硅内部结构发生了改变,较为准确的单晶硅的硬度测量值为 15.7 GPa。